

GN 7072.1 | Dismountable split set collars

with threaded holes, stainless steel



- 1
- 2
- 3
- 4
- 5
- 6
- 7
- 8
- 9
- 10
- 11
- 12
- 13
- 14
- 15
- 16
- 17
- 18

STANDARD EXECUTIONS

Sintered AISI 316 LHC stainless steel.
Clamping assembly by means of two AISI 304 stainless steel screws, cylindrical head with hexagon socket.
Threaded pass-through holes d3 when $d1 = 30 \div 36$.
Threaded blind holes d3 when $d1 \geq 42$.
- **GN 7072.1-A**: with radial threaded holes.
- **GN 7072.1-B**: with axial threaded holes.

FEATURES AND APPLICATIONS

GN 7072.1 dismountable split set collars are assembled and fixed to the shaft by tightening the screw properly. The threaded holes allow to fix brackets for sensor holders GN 7062.10 (see page -) on shafts. They can be used not only as end stops, but also for fixing other components, such as end limit switches.
Compared to the single-body set collars, the dismountable split set collars can be positioned on the shaft without having to insert them from the end.
The clamping screws d3 may be replaced by clamping kit GN 311 (see page -).

TECHNICAL DATA

Assembly on h11 tolerance shafts.

ACCESSORIES

- Dampening washers GN 7072.30 (see page -).
- Sensor holders GN 7062.10 (see page -).



GN 7072.1-A

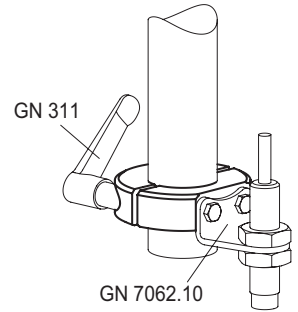
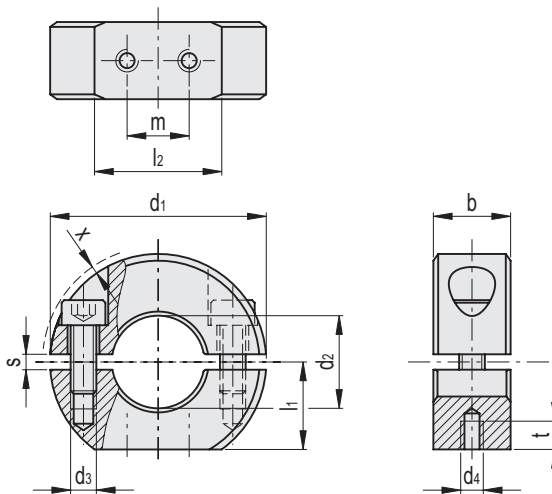

Conversion Table	
1 mm = 0.039 inch	
d1	
mm	inch
30	1.18
32	1.26
36	1.42
42	1.65
48	1.89
55	2.17
60	2.36
65	2.56

GN 7072.1-A

Code	Description	d1	d2 H10	d3	d4	b±0.2	l1	l2	m	s	t	x*	d3 Clamping kit	△
GN.75201	GN 7072.1-30-B12-NI-A	30	12	M4	M3	11	13	15	8	2.1	4	0.7	GN 311-30-M4-12-SW	36
GN.75206	GN 7072.1-32-B14-NI-A	32	14	M4	M3	11	14	15.5	8	2.1	4	0.7	GN 311-30-M4-12-SW	39
GN.75211	GN 7072.1-36-B15-NI-A	36	15	M5	M4	13	15	19.9	10	2.1	5.5	1.4	GN 311-30-M5-13-SW	65
GN.75216	GN 7072.1-36-B16-NI-A	36	16	M5	M4	13	15	19.9	10	2.1	5.5	1.4	GN 311-30-M5-13-SW	58
GN.75221	GN 7072.1-42-B18-NI-A	42	18	M5	M4	15	17	24.7	12	3	5.5	0.6	GN 311-30-M5-15-SW	92
GN.75226	GN 7072.1-42-B20-NI-A	42	20	M5	M4	15	17	24.7	12	3	5.5	0.6	GN 311-30-M5-15-SW	86
GN.75231	GN 7072.1-48-B22-NI-A	48	22	M5	M4	15	20	26.5	12	3	5.5	-	GN 311-45-M5-16-SW	119
GN.75236	GN 7072.1-48-B25-NI-A	48	25	M5	M4	15	20	26.5	12	3	5.5	-	GN 311-45-M5-16-SW	108
GN.75241	GN 7072.1-55-B28-NI-A	55	28	M6	M5	15	22.5	31.6	18	3	7	0.5	GN 311-45-M6-18-SW	147
GN.75246	GN 7072.1-55-B30-NI-A	55	30	M6	M5	15	22.5	31.6	18	3	7	0.5	GN 311-45-M6-18-SW	137
GN.75251	GN 7072.1-60-B32-NI-A	60	32	M6	M5	15	25	33.2	18	4	7	0.4	GN 311-45-M6-19-SW	177
GN.75256	GN 7072.1-60-B35-NI-A	60	35	M6	M5	15	25	33.2	18	4	7	0.4	GN 311-45-M6-19-SW	150
GN.75261	GN 7072.1-65-B40-NI-A	65	40	M6	M5	15	27.5	34.6	18	4	7	0.5	GN 311-45-M6-20-SW	169



Standard machine parts

* Max protrusion of the screw head.



GN 7072.1-B

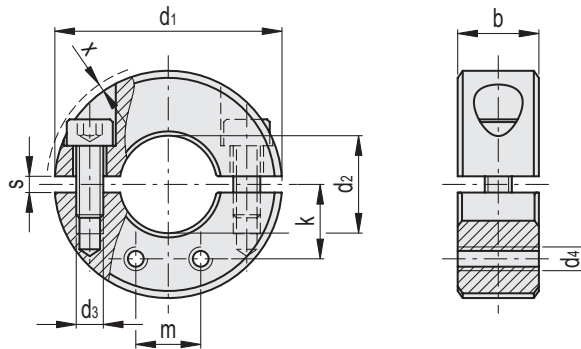

Conversion Table	
1 mm = 0.039 inch	
d1	
mm	inch
30	1.18
32	1.26
36	1.42
42	1.65
48	1.89
55	2.17
60	2.36
65	2.56

GN 7072.1-B

INOX STAINLESS STEEL METRIC

Code	Description	d1	d2 H10	d3	d4	b±0.2	m	k	s	x*	d3 Clamping kit	⚖
GN.75202	GN 7072.1-30-B12-NI-B	30	12	M4	M3	11	8	9.7	2.1	0.7	GN 311-30-M4-12-SW	37
GN.75207	GN 7072.1-32-B14-NI-B	32	14	M4	M3	11	8	10.8	2.1	0.7	GN 311-30-M4-12-SW	40
GN.75212	GN 7072.1-36-B15-NI-B	36	15	M5	M4	13	10	11.7	2.1	1.4	GN 311-30-M5-13-SW	68
GN.75217	GN 7072.1-36-B16-NI-B	36	16	M5	M4	13	10	12	2.1	1.4	GN 311-30-M5-13-SW	60
GN.75222	GN 7072.1-42-B18-NI-B	42	18	M5	M4	15	12	13.7	3	0.6	GN 311-30-M5-15-SW	96
GN.75227	GN 7072.1-42-B20-NI-B	42	20	M5	M4	15	12	14.3	3	0.6	GN 311-30-M5-15-SW	91
GN.75232	GN 7072.1-48-B22-NI-B	48	22	M5	M4	15	12	16.4	3	-	GN 311-45-M5-16-SW	125
GN.75237	GN 7072.1-48-B25-NI-B	48	25	M5	M4	15	12	17.2	3	-	GN 311-45-M5-16-SW	113
GN.75242	GN 7072.1-55-B28-NI-B	55	28	M6	M5	15	18	18.7	3	0.5	GN 311-45-M6-18-SW	153
GN.75247	GN 7072.1-55-B30-NI-B	55	30	M6	M5	15	18	19.3	3	0.5	GN 311-45-M6-18-SW	145
GN.75252	GN 7072.1-60-B32-NI-B	60	32	M6	M5	15	18	21.2	4	0.4	GN 311-45-M6-19-SW	186
GN.75257	GN 7072.1-60-B35-NI-B	60	35	M6	M5	15	18	22	4	0.4	GN 311-45-M6-19-SW	157
GN.75262	GN 7072.1-65-B40-NI-B	65	40	M6	M5	15	18	24.7	4	0.5	GN 311-45-M6-20-SW	178

* Max protrusion of the screw head.